

Operators for swing gates up to 1000 lbs weight and 20 ft length. Strong, with articulated arm, ideal for **commercial applications.**



5 year commercial warranty

7 year residential warranty

24 V motors, 120 Vac main power.

Easy to program: speed, force, sensitivity to obstacles and other parameters can be simply adjusted according to specific site and installation conditions and needs.

Easy to install: all parts requiring initial adjustment, such as the limit switches, are easily accessible. Thanks to the pivot support, the integrated control unit 1050 can be tilted to make programming more comfortable: its large LCD user-friendly display shows the status of the operator and allows easy visual observation of the input LEDs.

Innovative: the integrated 1050 control unit offers several features, such as 7 day programming, protection against electric shocks, programmable connections to external accessories such as lights, keypads, etc.

Plug-in receiver: up to 1,000 rolling-code transmitters, with more than 2X range than industry standard.

Master/slave management: two units synchronized for dual application.

Reliable: the operator is safely protected from water and dust by the cover which can be easily removed to rely on mechanical release in case of need.

Long-time protection from corrosion.

Smart management of the battery charging. Solar power compatible.

| Code | Description | Approvals |
|---------------|--|-----------|
| 4300SW | Operator 24 Vdc for swing gates up to 600 lbs weight and 16 ft length. ½ HP. Integrated control unit 1050. Ideal for residential applications. | ETL |
| 4500SW | Operator 24 Vdc for swing gates up to 1000 lbs weight and 20 ft length. 1 HP. Integrated control unit 1050. Ideal for commercial applications. | ETL |

Technical specifications

| Code | 4300SW | 4500SW |
|---|----------------|--------|
| Electrical data | | |
| Power Supply (Vac 60Hz) | | 120 |
| Operation (Vdc) | | 24 |
| Performance data | | |
| Maximum speed (Rpm) | | 1.8 |
| Maximum speed (seconds for 90° opening) | | 12-18 |
| Maximum torque (Nm) | 550 | 850 |
| Dimensional and general data | | |
| Size (inches, length x width x height) | 18.1x18.5x27.5 | |
| Operator weight (lbs) | 150 | 155 |

Gate setup

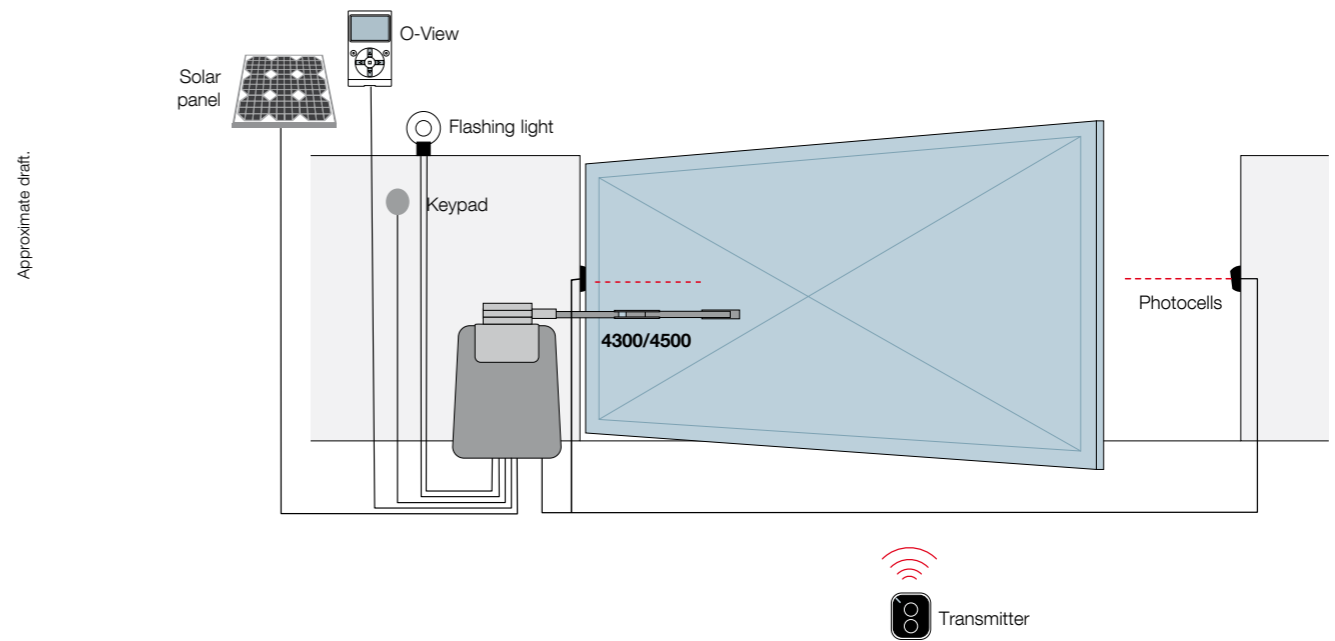

Approximate draft:

Nice transmitters and accessories to control and make safer your automation system:



INTI
2-channel transmitters 433.92 MHz, rolling code system with self-learning function. Available in 6 different colors.



ERA ONE
2, 4-channel 433.92 MHz transmitters with management of Identity Codes and Certificates.



MOTB
12-key digital selector.



MOFB
One couple of photocells.



ML24T
Flashing light with integrated aerial.



LP1 - LP2
Loop detectors.

Dimensions

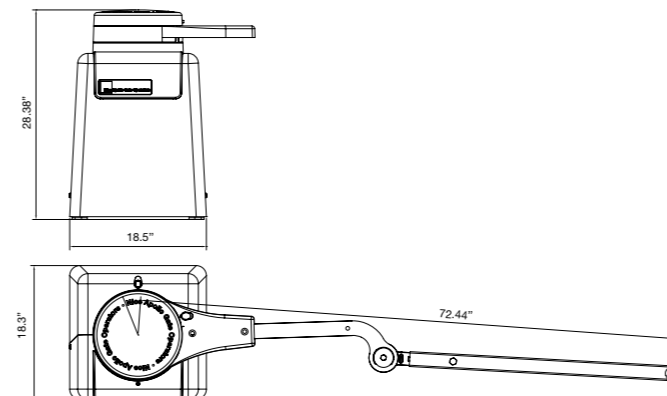

Application



Reliable in any condition. Strong, for swing gates up to 1000 lbs and 20 ft.