

# LARGE

# ROLLING CENTER

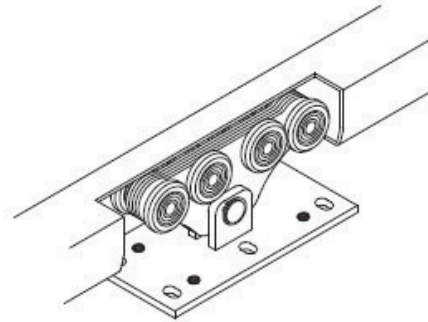

- I** Carrello "Medio" per cancelli autoportanti
- UK** "Medium" carriage for cantilever gates
- D** "Medium" Rollenapparat fuer freitragende Schiebtore
- F** Chariot "Moyen" pour portails autoportants
- E** Carril "Medio" par cancelas autoportantes esidenciales
- RUS** Средняя тележка для раздвижных ворот



Articolo - Article	L1	Peso max cancello Gate max weight	Abbinabile Combining	
Riferimento - Reference	Max ML			N°
CA 4 RS	LT 00 80 80	8	600	GIPI 4 RG / GZ
				2
				21

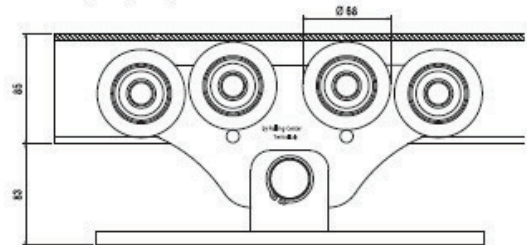
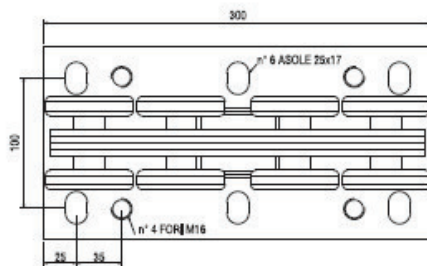
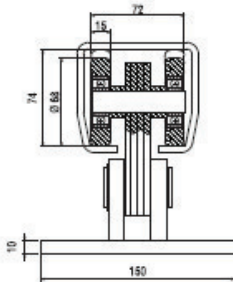

Peso max cancello Gate max weight	L1 (mt)	L2 (mt)	L4 (mt)	L5 (mt)	LT (mt)	H (mt)	E (mt)	A (mt)	B (mt)	C (mt)	Portata max carrello Carriage strength	Fondazione Armatura
600	4,0	1,20	2,2	0,2	6,2	1,7	0,3	2,5	0,6	0,5	1200	4 Ø 12 4 Ø 12
600	5,0	1,50	2,5	0,2	7,5	1,7	0,3	2,8	0,6	0,5	1200	4 Ø 12 4 Ø 12
600	6,0	1,80	2,8	0,2	8,8	1,7	0,3	3,2	0,6	0,5	1200	4 Ø 12 4 Ø 12
600	7,0	2,10	3,1	0,2	10,1	1,7	0,3	3,7	0,6	0,5	1200	7 Ø 12 4 Ø 12
600	8,0	2,40	3,4	0,2	11,4	1,7	0,3	3,7	0,6	0,5	1200	7 Ø 12 4 Ø 12

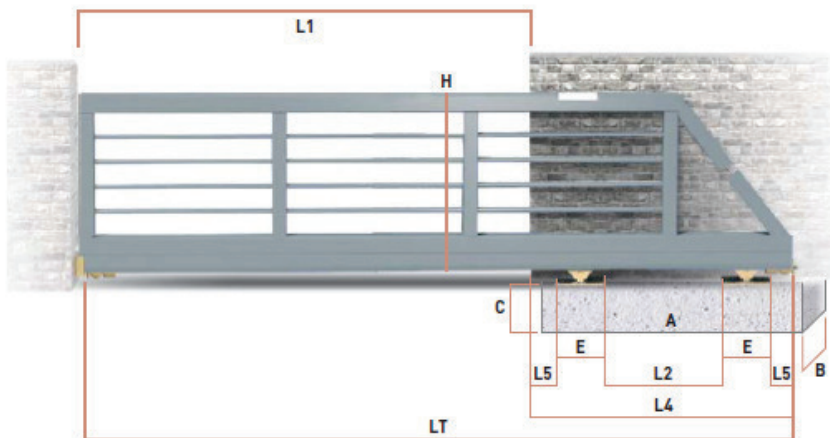
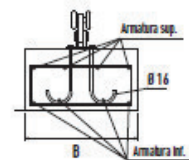

LT = L1+L4      L2 = 30% di L1      L4 = L2+(E+L5) x2

### Accessori Abbinabili / Combining accessories

CA4RS  x2	41 P  x2
50 P  x2	GIPI4RG/Z  *
4RM P  x2	Gloeck  x1

\* Lunghezza guida variabile  
Variable track length