

MAGNUM

ROLLING CENTER



- I** Carrello "Magnum" per cancelli autoportanti
- UK** Cantilever "Magnum" gate carriage with brush - holder
- D** Freitragendes "Magnum" Gatterwagen mit Bürstenhalter
- F** Chariot "Magnum" pour portail autoportant avec porte - brosse
- E** Carril "Magnum" par cancelas autoportantes con cepillo pequeño
- RUS** Тележка «Магнум» для раздвижных ворот со щетками

Articolo - Article	L1	Peso max cancello Gate max weight	Abbinabile Combining		
Riferimento - Reference	Max ML			N°	
CA 4 RMS LT 01 20 80	16	1200	GIPI 4 RM / MG	1	44,6

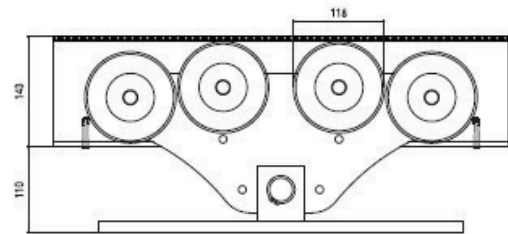
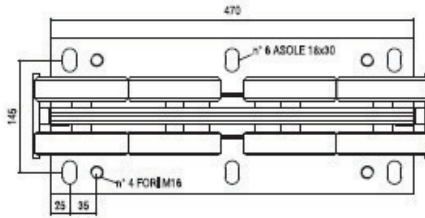
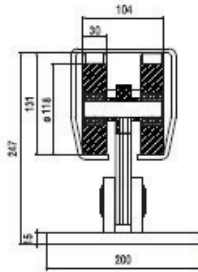
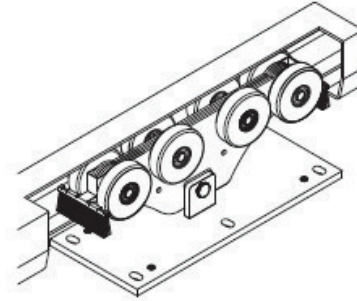

Peso max cancello Gate max weight	L1 (mt)	L2 (mt)	L4 (mt)	L5 (mt)	LT (mt)	H (mt)	E (mt)	A (mt)	B (mt)	C (mt)	Portata max carrillo Carriage strength	Fondazione Armatura	
1200	9,0	2,7	4,04	0,2	13,0	1,7	0,47	4,2	0,6	0,5	2400	6 Ø 12	4 Ø 12
1200	10,0	3,0	4,34	0,2	14,3	1,7	0,47	4,2	0,6	0,5	2400	6 Ø 12	4 Ø 12
1200	11,0	3,3	4,64	0,2	15,6	1,7	0,47	4,8	0,8	0,6	2400	7 Ø 12	4 Ø 12
1200	12,0	3,6	4,94	0,2	16,9	1,7	0,47	4,8	0,8	0,6	2400	7 Ø 12	4 Ø 12
1200	13,0	3,9	5,24	0,2	18,2	1,7	0,47	5,4	0,8	0,6	2400	9 Ø 12	4 Ø 12
1200	14,0	4,2	5,54	0,2	19,5	1,7	0,47	5,4	0,8	0,6	2400	9 Ø 12	4 Ø 12
1200	15,0	4,5	5,84	0,2	20,8	1,7	0,47	6	0,8	0,6	2400	10 Ø 12	4 Ø 12
1200	16,0	4,8	6,14	0,2	22,1	1,7	0,47	6,2	0,8	0,6	2400	10 Ø 12	4 Ø 12

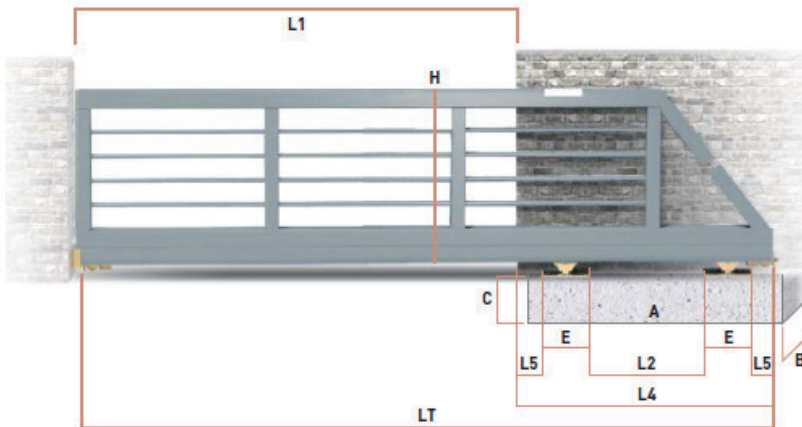
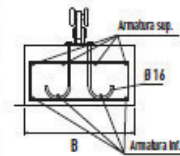

LT = L1+L4 L2 = 30% di L1 L4 = L2+(E+L5) x2

Accessori Abbinabili / Combining accessories

CA4RMS  x2	41 G  x2
50 G  x2	GIPI4RM/Z  *
2RG Z / 4RG P  x2	Gloeck  x1

* Lunghezza guida variabile
Variable track length