



For swing gates with leaves up to 5 m.

Electromechanical gear motor, surface mounted.
Also available in 24 Vdc version, with magnetic encoder.
Ideal for residential and industrial use.

New third generation models:

quality and durability thanks to the housing, made up of two tough aluminium shells with polyester paint finish; more resistant to atmospheric agents.

Internal moving parts completely in steel, light alloys and technopolymers.

Reliable and silent:

patented layout of internal parts.

Lead nut in bronze

for strength and silent operation.

Generously sized and practical connection compartment:

rapid and easy access from above to internal parts located in the upper section of the motor.

Simple installation and maintenance,

with built-in capacitor.

Total interchangeability

with the series Moby: identical positions and fixing brackets.

TO5024I ideal for intensive work load, thanks to the torque of 2200 Nm, can work on continuous duty on large sized gates.

Recommended control units:

Mindy A3, A3F, A6, A6F, A60, A700F; for TO5024 and TO5024I Moonclever MC824H.

24 Vdc version

with magnetic encoder. Perfect for intensive use, compatible with the control unit Moonclever MC824H, equipped with BlueBUS, and provision for operation with the systems Solemyo and Opera:

- simple programming, by means of a single key;
- self-learning of opening and closing limit positions;
- automatic fault diagnostics;
- programming of pause time;
- pedestrian pass door;
- deceleration on opening and closing;
- obstacle detection with dual technology;
- operation in event of power failure by means of optional rechargeable batteries (PS324);
- provision for connection of latest generation resistive sensitive edges.

Technical specifications

Code	TO5024	TO5024I	TO5015	TO5016	TO5605
Electrical data					
Power supply (Vac 50 Hz)	-	-	230		
Power supply (Vdc)	24	-	-		
Absorption (A)	5	-	1.5	-	1.3
Power (W)	120	-	340	-	300
Built-in capacitor (µF)	-	-	7		
Performance data					
Speed (m/s)	0.016	-	0.013*	-	0.016
Force (N)	1800	2200	1800		
Work cycle (cycles/hour)	95*	75**	54	-	50
Dimensional and general data					
Protection level (IP)	44				
Working temp. (°C Min/Max)	-20 ÷ +50				
Dimensions (mm)	965x115x105 h				
Weight (kg)	7				

* With optimal installation.

** The reduction in number of manoeuvres with respect to the version TO5024 depends solely on the lower manoeuvre speed.

Installation diagram

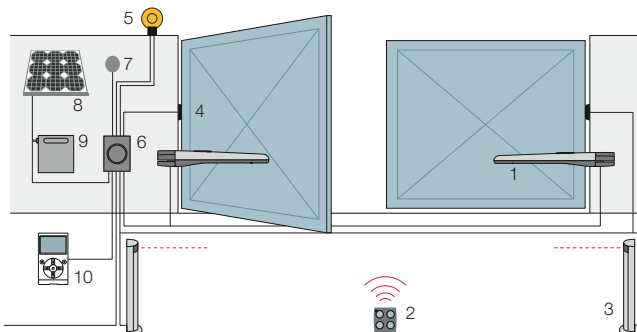

1. Toona
 2. Transmitter
 3. Photovoltaic cells mounted on posts
 4. Photovoltaic cells
 5. Flashing light
 6. Control unit
 7. Digital or key switches
 8. SYP* solar panel
 9. PSY24* battery box
 10. O-View* multifunction display.
- *Optional connection to Solemyo and Opera systems.

Utilisation limits

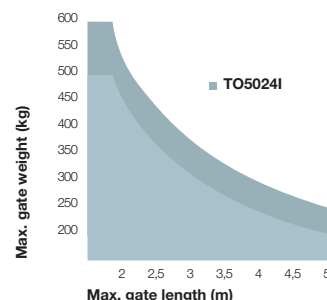

The shape, the height of the gate and the weather conditions can considerably reduce the values shown in the graph to the side. Use in windy areas 230 Vac models.