



The strong solution, for sliding gates

SL10S kit

Kit for automation of a residential sliding gate
weighing up to 550 kg and 7 m max. long.

New:

Compatibility with MhouseKit PF, the kit for Solar power automations, to automate gates without the need for connections to the electrical mains, even in locations far away or difficult to access.

New Design for accessories.

Reliable and noiseless: mechanical parts made of metal, die-cast painted aluminium base, gear motor mounted on bearings.

No waiting in front of the gate: only 23 seconds to open and close (in perfect installation conditions, for a sliding gate 4 m long).

Extra safe thanks to the low-voltage connections (24 V), the safety accessories and the automatic obstacle detection feature.

Auto-programming: automatically calculates the most suitable operating parameters for each gate.

Autodiagnostic system identifies and immediately signals any connection errors or malfunctions.

Modular control card with integrated receiver

- 2 speeds
- Timed and adjustable automatic closing function
- Programming of new transmitters (up to 150)
- Adjustable partial opening function
- Pause time adjustment
- Obstacle sensitivity adjustment
- Automatic recognition of NC-NO-8.2 KOhm safety devices, if installed.

Quick motor release for manual gate operation.

No black-out: the buffer batteries guarantee up to ten opening and closing manoeuvres even in the event of power outages (accessory).

Each Kit SL10S contains:



1 SL10SC Electromechanical gear motor with integrated control unit and 433.92 MHz variable code receiver. 3 Mhouse release keys and mounting plate included.



2 GTX4 433.92 MHz, 4 button variable code transmitters. Practical wall rest included in the package.



PH100 Pair of wall-mounted autosynchronized photocells.



FL100 Adjustable flashing light, with built-in aerial.

Optional accessories



PF Solar power kit.

PBC Battery charger power supply unit, for PF.



DS1 13-key digital switch with programmable code, via radio.



KS100 Two-position (open/stop) key-operated selector switch with pair of metal keys.



PT50 Two 485 mm high posts including one pair of photocells.

PT100 Two 945 mm high posts including two pairs of photocells.



PR1 24 V buffer battery for emergency power supply.



CR100 Nylon gear rack with steel core, four 1-metre sections
CR25 one 1-metre sections.

Installation

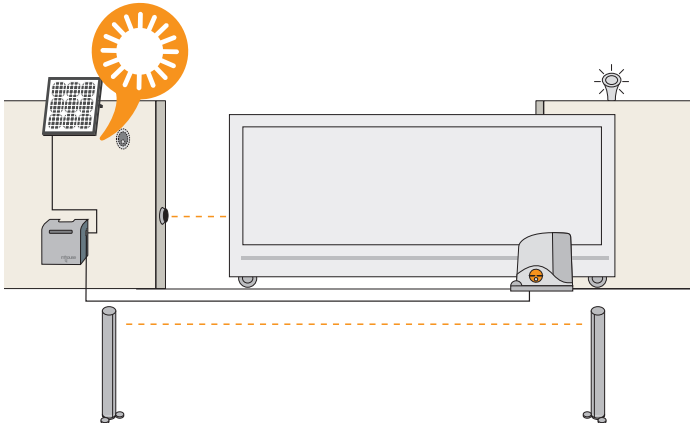

Technical characteristics

Power supply (Vac)	110
Power (W)	420
Thrust (N)	475
Speed (m/sec)	0.12 ÷ 0.18
Protection class (IP)	44
Weight (kg)	10
Certification	CE

For updated and complete information, consult the product technical manual.

Packaging characteristics

Package dimensions (mm)	560x210x360
Package weight (kg)	11.80
Palletization (pz)	21
EAN Code	8032595792284

The content of the package may vary: consult the retailer

